



# Huawei CloudEngine 5882 Switch Datasheet

CloudEngine 5882 switches provide high-density GE access to help enterprises build a scalable data center network platform for cloud computing.

# Product Overview

Huawei CloudEngine 5882 series switches are next-generation, high-density Gigabit Ethernet switches designed for data centers. The CloudEngine 5882 hardware has an advanced architectural design, providing high-density GE access ports and 10GE uplink ports. Using the Huawei VRP software platform, CloudEngine 5882 switches support rich features. In addition, the airflow direction (front-to-back or back-to-front) can be changed. CloudEngine 5882 switches can work with CloudEngine 16800 or CloudEngine 12800 switches to build an elastic, virtualized, high-quality fabric that meets the requirements of cloud-computing data centers.

CloudEngine 5882 switches provide high-density GE access to help enterprises build a scalable data center network platform for cloud computing.

## Product Appearance

CloudEngine 5882-48T4S provides 48\*GE BASE-T ports, 4\*10GE SFP+ ports.



## Product Characteristics

### High-density GE Access

- Each CloudEngine 5882 switch provides 48\*GE line-speed ports, which makes future data center expansion easy.
- The CloudEngine 5882 switch provides 10GE uplink ports. The CloudEngine 5882 switches can work with CloudEngine 16800 or CloudEngine 12800 switches to build a high-performance data center network.

### Programmable Network Device, Flexible Customization

- The CloudEngine 5882 uses the Open Programmability System (OPS) embedded in the VRP software platform to provide programmability at the control plane.
- The OPS provides open APIs. APIs can be integrated with mainstream cloud platforms (including commercial and open cloud platforms) and third-party controllers. The OPS enables services to be flexibly customized and provides automatic management.
- Users or third-party developers can use open APIs to develop and deploy specialized network management policies to implement extension of fast service functions, automatic deployment, and intelligent management. The OPS also implements automatic operation and maintenance, and reduces management costs.
- The OPS provides seamless integration of data center service and network in addition to a service-oriented, software-defined networking (SDN).

### Flexible Airflow Design, High Energy Efficiency

- Flexible front-to-back/back-to-front airflow design
  - » The CloudEngine 5882 uses a front-to-back/back-to-front airflow design that isolates cold air channels from hot air channels. This design meets heat dissipation requirements in data center equipment rooms.
  - » Air can flow from front to back, or back to front when different fans and power modules are used.
  - » Redundant power modules and fans can be configured to ensure uninterrupted service transmission.
- Energy-saving technology

» The CloudEngine 5882 has energy-saving chips and can measure system power consumption in real time. Fan speeds can be adjusted dynamically based on system consumption. These energy-saving technologies reduce O&M costs and contribute to a greener data center.

## Clear Indicators, Simple Maintenance

- Clear indicators
- » Port indicators clearly show the port status.
- » State and stack indicators on both the front and rear panels enable operators to maintain the switch from either side.
- » CloudEngine 5800 switches support remote positioning. Operators can turn on remote positioning indicators on the switches they want to maintain, so that they can find switches easily in an equipment room full of devices.

## Product Specifications

Note: This content is applicable only to regions outside mainland China. Huawei reserves the right to interpret this content.

### Functions and Features

Item	CloudEngine 5882-48T4S
Device virtualization	iStack
Programmability	Open Programmability System (OPS)
Traffic analysis	NetStream
	Telemetry
VLAN	Adding access, trunk, and hybrid interfaces to VLANs
	Default VLAN
	QinQ
	MUX VLAN
	GVRP
MAC address table	Dynamic learning and aging of MAC addresses
	Static, dynamic, and blackhole MAC address entries
	Packet filtering based on source MAC addresses
	MAC address limiting based on ports and VLANs
IP routing	IPv4 routing protocols, such as RIP, OSPF, BGP, and IS-IS
	IPv6 routing protocols, such as RIPng, OSPFv3, IS-ISv6, and BGP4+.
IPv6	IPv6 Neighbor Discovery (ND)
	Path MTU Discovery (PMTU)
	TCP6, ping IPv6, tracer IPv6, socket IPv6, UDP6, and raw IPv6
Multicast	IGMP, PIM-SM, PIM-DM, MSDP, and MBGP
	IGMP snooping
	Fast leaving of multicast member interfaces
	Multicast traffic suppression

Item	CloudEngine 5882-48T4S
	Multicast VLAN
Reliability	LACP
	STP, RSTP, VBST, MSTP
	BPDU protection, root protection, and loop prevention
	Smart Link and multi-instance
	DLDP
	ERPS (G.8032)
	VRRP, VRRP load balancing, and BFD for VRRP
	BFD for BGP/IS-IS/OSPF/Static route
QoS	Traffic classification based on Layer 2 headers, Layer 3 protocols, Layer 4 protocols, and 802.1p priority
	Actions of ACL, CAR, re-marking, and scheduling
	Queue scheduling algorithms, including DRR, SP, and DRR+SP
	Congestion avoidance mechanisms, including WRED
	Traffic shaping
Configuration and maintenance	Console, Telnet, and SSH terminals
	Network management protocols, such as SNMPv1/v2/v3
	File upload and download through FTP and TFTP
	BootROM upgrade and remote upgrade
	802.3az Energy Efficient Ethernet (EEE)
	Hot patches
	User operation logs
Security and management	Command line authority control based on user levels, preventing unauthorized users from using commands
	DoS, ARP, and ICMP attack defenses
	Port isolation, port security, and sticky MAC
	Binding of the IP address, MAC address, interface number, and VLAN ID
	Authentication methods, including AAA, RADIUS, and HWTACACS
	Remote Network Monitoring (RMON)

## Performance and Scalability

Item	CloudEngine 5882-48T4S
Maximum number of MAC address entries	288K
Maximum number of Forwarding routes (FIB IPv4/ IPv6)	512K/64K
ARP table size	128K
Maximum number of VRF	1023

Item	CloudEngine 5882-48T4S
IPv6 ND (Neighbor Discovery) table size	16K
Maximum Number of multicast routes (Multicast FIB IPv4/IPv6)	16K/16K
Maximum VRRP groups	64
Maximum number of ECMP paths	FIB4:16;FIB6:8
Maximum ACL number	4K
Maximum number of E-Trunk	16
Maximum number of links in a E-Trunk	64
Maximum number of MSTP instance	64
VBST (Maximum number of VLANs where VBST can be configured)	300

NOTE: This specification may vary between different scenarios. Please contact Huawei for details.

## Hardware Specifications

Item	CloudEngine 5882-48T4S	
Physical features	Dimensions (W x D x H)	442 mm x 420 mm x 43.6 mm
	Weight (excluding optical transceivers, power modules, and fan assemblies, including AC power modules and fan assemblies, excluding optical transceivers; kg)	8.55
	Switching capacity (Gbps)	336
	Forwarding performance (Mpps)	125
Number of GE Base-T ports		48
Number of 10GE SFP+ ports		4
Card	Number of card slot	0
	Card type	Fixed switch
Management interface	Out-of-band management port	1*GE management interface
	Console port	1*RJ45 interface
	USB port	1
CPU	Main frequency (GHz)	1.4
	Number of cores	4
Storage	RAM	4 GB
	NOR flash	64 MB
	NAND flash	1 GB
System	System buffer	8 MB
Power supply system	Power modules	150 W AC/180 W -48 V DC
	Rated voltage range (V)	AC: 100 V to 240 V DC: -48 V to -60 V

Item		CloudEngine 5882-48T4S
	Maximum voltage range (V)	AC: 90 V to 290 V DC: -38.4 V to -72 V
	Maximum input current	100 V to 240 V 3A -48 V to -60 V DC 6A
	Typical power	101 W (30% throughput) 104 W (100% throughput)
	Maximum power	124 W
	Frequency (AC, HZ)	50/60
Heat dissipation	Heat dissipation mode	Air cooling
	Number of fan trays	2
	Heat dissipation airflow	Front-to-back or back-to-front airflow
	Maximum heat consumption (BTU/hr)	423
Environment specifications	Long-term operating temperature (°C)	-5°C to 45°C (0-1800 m) The temperature decreases by 1°C each time the altitude increases by 220 m.
	Storage temperature (°C)	-40°C to +70°C
	Relative humidity	5% to 95%
	Operating altitude (m)	Up to 5000
	Surge protection	AC power supply protection: 6 kV in common mode and 6 kV in differential mode DC power supply protection: 4 kV in common mode and 2 kV in differential mode
Reliability	MTBF (year)	55.31
	MTTR (hour)	2
	Availability	> 0.99999

NOTE: For detailed information of CloudEngine 5800 platform hardware information, visit <https://support.huawei.com/enterprise/en/doc/EDOC1000019246?idPath=7919710%7C21782165%7C21782239%7C22318540%7C7597815>.

## Safety and Regulatory Compliance

The following table lists the safety and regulatory compliance of CloudEngine switches.

Certification Category	Description
Safety	<ul style="list-style-type: none"> <li>• IEC 60950-1</li> <li>• EN 60950-1/A11/A12</li> <li>• UL 60950-1</li> <li>• CSA C22.2 No 60950-1</li> <li>• AS/NZS 60950.1</li> <li>• CNS 14336-1</li> <li>• IEC60825-1</li> <li>• IEC60825-2</li> </ul>

Certification Category	Description
	<ul style="list-style-type: none"> <li>EN60825-1</li> <li>EN60825-2</li> </ul>
Electromagnetic Compatibility (EMC)	<ul style="list-style-type: none"> <li>CISPR22 Class A</li> <li>CISPR24</li> <li>EN55022 Class A</li> <li>EN55024</li> <li>ETSI EN 300 386 Class A</li> <li>CFR 47 FCC Part 15 Class A</li> <li>ICES 003 Class A</li> <li>AS/NZS CISPR22 Class A</li> <li>VCCI Class A</li> <li>IEC61000-4-2</li> <li>ITU-T K 20</li> <li>ITU-T K 21</li> <li>ITU-T K 44</li> <li>CNS13438</li> </ul>
Environment	<ul style="list-style-type: none"> <li>RoHS</li> <li>REACH</li> <li>WEEE</li> </ul>

#### Note

- EMC: electromagnetic compatibility
- CISPR: International Special Committee on Radio Interference
- EN: European Standard
- ETSI: European Telecommunications Standards Institute
- CFR: Code of Federal Regulations
- FCC: Federal Communication Commission
- IEC: International Electrotechnical Commission
- AS/NZS: Australian/New Zealand Standard
- VCCI: Voluntary Control Council for Interference
- UL: Underwriters Laboratories
- CSA: Canadian Standards Association
- IEEE: Institute of Electrical and Electronics Engineers
- RoHS: restriction of the use of certain hazardous substances
- REACH: Registration Evaluation Authorization and Restriction of Chemicals
- WEEE: Waste Electrical and Electronic Equipment

## Supported MIBs

For details about the MIB information, visit

<https://support.huawei.com/hedex/hdx.do?docid=EDOC1100101219&lang=en&idPath=24030814%7C21782165%7C21782239%7C22318540%7C7597815>.

## Optical Transceivers and Cable

For details about optical transceivers and cables, visit

<https://e.huawei.com/en/material/networking/dcs/switch/f6d91cf16df0474998087676a33fd41e>.

# Ordering Information

Mainframe		
CE5882-48T4S	CE5882-48T4S Switch (48*GE RJ45, 4*10GE SFP+, without power and fan modules)	
CE5882-48T4S-B	CE5882-48T4S Switch (48*GE RJ45, 4*10GE SFP+, with dual AC power and fan modules, port-side air intake)	
CE5882-48T4S-F	CE5882-48T4S Switch (48*GE RJ45, 4*10GE SFP+, with dual AC power and fan modules, port-side air exhaust)	
Power		
Part Number	Product Description	Support Product
PAC150S12-R	150W AC Power Module	CE5882-48T4S
PDC180S12-CR	180W DC Power Module	CE5882-48T4S
Fan		
Part Number	Product Description	Support Product
FAN-023A-B	Fan box(B,FAN panel side exhaust)	CE5882-48T4S
FAN-031A-F	Fan box(F,FAN panel side intake )	CE5882-48T4S

## Networking and Application

### Data Center Applications

On a typical data center network, CloudEngine 16800/CloudEngine 12800/ CloudEngine 8800switches work as core switches, whereas CloudEngine 8800/CloudEngine 6800/CloudEngine 5800 switches work as ToR switches and connect to the core switches using 100GE/40GE/10GE ports. These switches use a fabric protocol, such as CSS or M-LAG, to establish a non-blocking large Layer 2 network, which allows large-scale VM migrations and flexible service deployments.

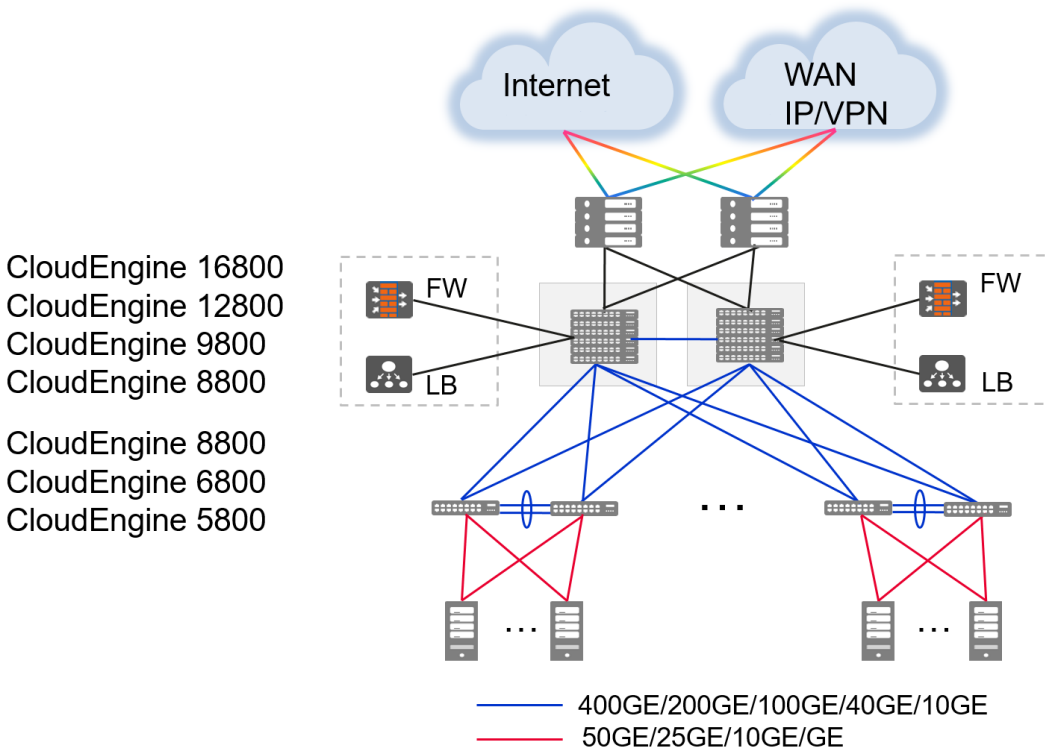



**Copyright © Huawei Technologies Co., Ltd. 2021. All rights reserved.**

No part of this document may be reproduced or transmitted in any form or by any means without prior written consent of Huawei Technologies Co., Ltd.

#### **Trademarks and Permissions**



HUAWEI and other Huawei trademarks are trademarks of Huawei Technologies Co., Ltd.

All other trademarks and trade names mentioned in this document are the property of their respective holders.

#### **Notice**

The purchased products, services and features are stipulated by the contract made between Huawei and the customer. All or part of the products, services and features described in this document may not be within the purchase scope or the usage scope. Unless otherwise specified in the contract, all statements, information, and recommendations in this document are provided "AS IS" without warranties, guarantees or representations of any kind, either express or implied.

The information in this document is subject to change without notice. Every effort has been made in the preparation of this document to ensure accuracy of the contents, but all statements, information, and recommendations in this document do not constitute a warranty of any kind, express or implied.

#### **Huawei Technologies Co., Ltd.**

Address: Huawei Industrial Base Bantian, Longgang Shenzhen 518129 People's Republic of China

Website: [www.huawei.com](http://www.huawei.com)